

PARTS CLEANERS – AQUEOUS/SOLVENT [®]

Operations and Maintenance Instructions



TABLE OF CONTENTS

WARNINGS/CAUTIONS	2	REPLACEMENT PARTS	
INTRODUCTION	4	PNEUMATIC, ELECTRICAL AND HEATING	
LIFTKLEEN CONSTRUCTION FEATURES	4	COMPONENTS	15
TANK ASSEMBLY	4	PUMP ASSEMBLY	16
PLATFORM AND LIFTER ASSEMBLY	4	AIR CYLINDERS	16
SUPERFLO PUMP ASSEMBLY	4	MISC. MECHANICAL PARTS	16
COVER ASSEMBLY	5	FIGURES	
CONTROLS - PNEUMATIC and		1 BASIC ASSEMBLY LKR & LKD	
ELECTRIC	5	(SIDE, TOP)	17
INSTALLATION OF THE LIFTKLEEN	6	2 BASIC ASSEMBLY LKR & LKD	
SERVICE HOOK-UP	6	(SIDE)	17
FLOOR MOUNTING OF LIFTKLEEN	6	3 ELECTRICAL SCHEMATICS	18
OPERATION OF THE LIFTKLEEN	6	4a, b, c PNEUMATIC SYSTEMS	19
AGITATING LIFT PLATFORM	6	4d ANTI-TIE DOWN SYSTEMS	22
CYCLE TIMER (optional)	7	5A, B LKT-4 CYCLE TIMER	23
EMERGENCY STOP	7	6 MANUALLY OPENED COVER	24
ANTI-TIE DOWN DEVICE (optional)	7	7 CYLINDER OPERATED COVER	25
SUPERFLO PUMP (optional)	7	8 VALVE CONNECTIONS	26
ELECTRIC HEAT (optional)	7	9a, b FLOOR MOUNTING HOLE	
STEAM HEAT (optional)	7	LOCATIONS	27
HEATER TIMER (optional)	7	10 OPERATING SWITCHES	27
FILTRATION SYSTEMS (optional)	7	11 TEMPERATURE DIAL	27
LIFT PLATFORM MOTION		12 HEATUP TIME CHART	28
ADJUSTMENTS	8	13 SPEED CONTROL	29
SUPERFLO PUMP DISCHARGE		14 MASTER ON/OFF VALVE and	
DIRECTION ADJUSTMENTS	8	AIR FILTER/REGULATOR/	
MAINTENANCE	8	LUBRICATOR	29
LOCK OUT PROCEDURES	8	15 AIR LINE CONNECTION	29
LUBRICATION	8	16 PUMP ASSEMBLY	30
PNEUMATIC SYSTEM	8	17 SUPERFLO PUMP DISCHARGE	
TROUBLESHOOTING GUIDE	9	NOZZLE	30
TABLES		18 LUBRICATION POINTS	31
1 DIMENSIONS/SPECIFICATIONS	12	19 STEAM HEATING ARRANGEMENT ..	31
2 PLATFORM LOAD CAPACITY	13	20 LKF-100 FILTRATION SYSTEM	32
3 AIR CONSUMPTION DATA	13	21 LKF-22 FILTRATION SYSTEM	32
4 ELECTRICAL CURRENT		22 PNEUMATIC TUBING CONNECT/	
REQUIREMENTS	14	DISCONNECT	33
5 LIFTKLEEN FILTERS	14	23 "DOWN" AIR POWER DISCONNECT	33
		WARRANTY	34

WARNINGS/CAUTIONS

Read all of these **SAFETY INSTRUCTIONS** and those in the manual **BEFORE** installing or using this equipment. Keep this manual handy for reference/training.

SAFETY

You will find various types of safety information on the following pages and on the labels attached to Graymills equipment. The following Safety Statements explain their meaning:

- ▲ The Safety Alert Symbol means **ATTENTION! BECOME ALERT! YOUR SAFETY IS INVOLVED!**
- ▲ **DANGER** The **DANGER** Symbol means that failure to follow this safety statement **will** result in serious personal injury or death.
- ▲ **WARNING** The **WARNING** Symbol means that failure to follow this safety statement **might** result in serious personal injury or death.
- ▲ **CAUTION** The **CAUTION** Symbol means that failure to follow this safety statement **might** result in personal injury or property damage.
- ▲ **NOTE** The **NOTE** Symbol means failure to follow these instructions could cause damage to the equipment or cause it to operate improperly.

▲ CAUTION

Never work with equipment you feel may be unsafe. Contact your Supervisor immediately if you feel a piece of equipment is in an unsafe condition.

HEATED MACHINES ONLY – AQUEOUS

- This is a heated parts cleaner.

▲ WARNING

Use only nonflammable, non-combustible, water-based alkaline cleaning compounds. Graymills recommends Super Aquatene® 330 or 360 (General Purpose), Aquatene® 581 (General Purpose and Non-Ferrous Metals), Aquatene® 571 (Ferrous Metals Only), Low Foam GM390 or pH neutral, non-corrosive Super Biotene® GM550.

If you have any questions regarding the correct fluids to use in this unit, call Graymills at (773) 248-6825 and ask for Customer Service.

Do **NOT** fill with or contaminate cleaning fluid with any flammable or combustible material such as gasoline, alcohol, mineral spirits, etc. Drain parts to be cleaned of any flammable or combustible material before placing inside cleaning tank. Even small quantities can create a dangerous fire hazard.

Follow all directions, Warnings, Cautions and Dangers for the cleaning material being used.

▲ CAUTION

When making an initial batch of cleaning solution or when adding compound to a heated Liftkleen, follow manufacturer's directions exactly. Wear appropriate safety equipment as recommended. Add only small amounts at one time to prevent a sudden boiling and/or eruption of liquid which will create a hazardous condition. **NEVER** dump in a large quantity at one time.

▲ WARNING

Maximum operating temperature is 180°F. Higher temperatures will cause increased risk of personal injury and damage the unit. Remember, any temperature above 115°F can cause severe burns. Equipment itself will be hot. Use caution.

The operator and anyone working in or around the Liftkleen must be cautious of the hot tank contents (cleaning solution, platform, lid being closed, etc.) and of the steam which escapes when the lid is opened. Be sure everyone who works in or around the Liftkleen reads and understands how to use the chemicals or compounds being used, as well as the machine.

NOTE

Turn heater off when unit is to be idle for extended periods (overnight or weekends). Liquid could evaporate enough to damage heater coil.

▲ CAUTION

Pump intake is above heater coil. If solution does not circulate, liquid level is too low. Turn heater (an optional feature) and pump (an optional feature) off immediately. Failure to keep coil immersed can cause heater to burn out.

NOTE

If you have purchased a heated unit with a carbon steel tank, observe the following before using: Water-based cleaning materials will generate steam and water vapors. Surfaces above the liquid level will be subject to rusting (this condition exists with any manufacturer's unit). This is primarily surface rust and does not appreciably affect the serviceability of the unit. However, if your cleaning requirements cannot tolerate any rust or contamination, please contact the factory for information on stainless steel models before putting the unit into service. Also, be sure your cleaning material contains a rust inhibitor. (Check with your cleaning fluid supplier.) The Graymills Warranty does not cover rusting of carbon steel units used with water-based material.

UNHEATED MACHINES – SOLVENT

▲ WARNING

Do NOT install near open flames or heat. Do NOT smoke near parts cleaner.

Be sure to follow label instructions provided with any fluid used in this unit. Use only combustible fluids with a flash point of 104°F or higher. Graymills recommends Super or Regular Agitene® (flashpoint approx. 105°F). Do NOT use flammable materials such as gasoline or alcohol (under 100°F flashpoint). Use of such unauthorized materials can cause a health and safety hazard which might result in serious personal injury or death. If you have any questions regarding the correct fluids to use in this unit, call Graymills at (773) 248-6825 and ask for Customer Service.

Do NOT contaminate cleaning compounds with any flammable materials (less than 100°F flashpoint), such as gasoline, alcohol, etc. Drain parts to be cleaned of any flammable material before placing inside cleaning tank. Even small quantities can create a dangerous safety hazard.

▲ CAUTION

Unit is equipped with a fusible safety link cover mechanism designed to support the open lid at a slightly forward angle. In the event of a fire, the fusible link will melt at 165°F permitting the lid to slam shut, reducing oxygen supply to the fire.

HEATED AND UNHEATED MACHINES – AQUEOUS/SOLVENT

▲ WARNING

These units have moving parts, pinch-points and close tolerances. Always stand clear of lift platform and lid when operating as the lid could unexpectedly open or the platform operate. Never raise lift platform with lid closed. Keep hands and fingers away from tank when operating platform. (See the OPERATION section.)

Unit must be properly grounded to prevent electric shock hazard. Connect only to three prong outlet. Should cord become cracked, frayed or damaged in any way, it should be repaired immediately by a qualified electrician. Never use an extension cord.

Since operator safety at all times is a priority, we strongly recommend that, whether or not required by local code, this equipment be connected only into a power supply equipped with a "Ground Fault Interrupter" (GFI). All electrical connections should conform to national/local codes and be made by qualified personnel.

▲ CAUTION

Inspect optional pump, optional heater and all electrical cords, plugs, and fusible link each time unit is cleaned. Do NOT use if any wear or damage is noticed until impaired components are repaired or replaced. Never operate if fusible fire link is not in place and functional. Fill tank to recommended operating capacity range before plugging in power cord. (See Table 1, p. 12.)

▲ WARNING

DO NOT perform any maintenance work on Liftkleen without having the air shut-off valve in the "Off" position and main air lines to cylinders disconnected. Disconnect electrical power. Follow lock out procedures.

▲ CAUTION

If any cleaning solutions are splashed on clothing, remove wet clothing promptly and thoroughly wash body areas that have been in contact with the solution. Do NOT permit saturated clothing to remain in contact with skin. Consult manufacturer's Material Safety Data Sheet (MSDS).

Cleaning solutions may irritate skin and eyes. If splashed in eyes, flush thoroughly with water with lids open. Consult Material Safety Data Sheet (MSDS) and a physician. Always wear appropriate safety items such as gloves, apron, safety glasses or goggles.

▲ CAUTION

When cleaning, be sure parts are fully drained of any flammable or corrosive materials. Even small amounts could cause a hazardous situation.

All Liftkleen models are shipped pre-wired and need only be connected to the proper electrical supply (see nameplate for electrical requirements). This is the responsibility of the customer and should be done by qualified personnel. Graymills is not responsible for any damage caused by incorrect supply wiring.

Tanks should be cleaned out on a regular basis to prevent sludge from building up around heaters. Failure to do so could result in damage to the heaters. Graymills is not responsible for such damage.

INTRODUCTION

The Graymills Liftkleen is a heavy-duty multi-function, commercial type parts cleaner designed for both industrial and automotive applications. It is available for use with either heated aqueous or solvent cleaning solutions. Seven basic tank sizes are offered ranging from 170 gallon capacity to 667 gallons in capacity (see Table 1 for dimensional data). A pneumatic lift platform is provided on all models.

A number of optional features are available to tailor the unit to a specific cleaning application.

- Superflo Pumping Unit with an output of up to 10,000 gallons per hour.
- Filtration system for the cleaning solution.
- Roller conveyor platform (instead of standard grate), loading and unloading conveyors.
- Cleaning cycle and heater timers.
- Anti-Tie Down Device
- Three 4.5 KW electric, immersion type heaters and insulated tank depending on model.
- Steam heat

CONSTRUCTION FEATURES

The general arrangements of the Models LKR and LKD Liftkleen assemblies, including optional features, are shown in Figures 1 and 2. The following paragraphs describe specific construction details.

• TANK ASSEMBLY

The Liftkleen was designed to withstand the rugged demands of heavy-duty industrial and automotive parts cleaning. The tank is leak-tested after welding. The bottom of the tank utilizes double wall construction and is supported by four channels. Openings are provided to facilitate moving the Liftkleen with a fork-lift truck. A 1-1/2" NPT drain is located in the bottom of the tank to which permanent drain connections can be attached. An overflow port is part of the tank assembly and is intended for use with heated models only. A water fill port is located in the rear of the tank (see Figure 8) and consists of 3/4" NPT pipe nipple. On optional heated models, the tank sides and cover are insulated with 1" thick polystyrene foam (equal to two-plus inches of fiberglass).

• PLATFORM AND LIFTER ASSEMBLY

The Platform and Lifter Assembly are designed to handle loads specified for the particular model of Liftkleen (see Table 2). The platform consists of an angle iron frame which supports an open steel grate. The lifter assembly is made up of a channel weldment, platform support weldment, four support rollers with needle bearings and hardened shafts, and a pneumatic cylinder. (Air consumption data can be found in Table 3).

The rollers and bearings on all Model LKR and LKD units are located outside the tank and therefore never immersed in the cleaning solution. This helps keep moving parts lubricated. The standard open steel grate of the platform assembly can be replaced with the optional roller conveyor platform.

• PUMP ASSEMBLY

The Superflo Pumping Unit Assembly, an **available option** on all Model LKR and LKD units, is capable of providing 10,000 gallons per hour of flow and provides exceptional liquid agitation for quicker, more effective parts cleaning. It is especially effective on parts containing holes. The pump is a centrifugal unit and is driven by an electric motor.

- **COVER ASSEMBLY**

The internal cover is made of stainless steel to eliminate corrosion caused by vapor condensation. On **heated models**, opening and closing the lid is accomplished manually utilizing a counter balanced lid (Figure 6). An **optional pneumatically powered lid** is available on **heated** units (Figure 7). Lids, as well as tanks, are insulated on **heated** units.

Unheated units must be ordered with a pneumatically powered lid (Figure 7). The lid actuation system on these units contains a temperature sensitive automatic closing feature. In the event of a fire in the tank, the platform assembly lowers and the lid closes automatically.

▲ WARNING

Always stand clear of lid. To prevent injury, keep head, hands and body clear of the lid, lift platform and lift mechanism at all times. These units have moving parts, pinch-points and close tolerances. Always stand clear of the lift platform and lid when operating as the lid could unexpectedly open or the platform operate. Keep hands and fingers away from tank when operating platform.

▲ CAUTION

When turning air on or off or when operating the lift platform, stay clear of the lid, lift platform and operating mechanism as the lid could unexpectedly open or the platform operate.

- **PNEUMATIC CONTROLS**

The standard Liftkleen is furnished with a pneumatic system that raises and lowers the platform, a master on/off valve and a filter/regulator/ lubricator unit.

The **agitating lift platform** contains air controls that agitate the platform up and down through a range of five inches with a variable frequency of 20 to 40 strokes per minute. Stroke frequency depends on load and available air pressure. Adjustments to the system should be made under operating load conditions.

The **platform agitation system** consists of a control box with a 2-position oscillation switch, a start and a restart switch, a master on/off valve, a filter/regulator/lubricator unit, a pilot operated directional control valve and two limit valves.

The optional pneumatically opened lid control is incorporated with the platform agitation system.

Schematics and operation sequence sheets are presented in Figures 4a through 4c.

All pneumatic tubing connections are made with Instant Fittings. These make it possible to connect and disconnect the tubing to the fittings without the use of a wrench. To disconnect a tube, simply push in the brass or plastic collet with a screwdriver tip and pull the tube from the socket. To engage the tube, push it into the fitting until it hits the stop. Sealing of the connection is achieved with an O-Ring in the fitting. This procedure is shown in detail in Figure 22.

The air cylinder for raising, lowering and oscillating (agitating) the work platform has pneumatic lines connected to both its “up” and “down” ports. This provides for smooth, positive, controlled motion in both travel directions with minimal dependence on the weight of the work load.

- **ELECTRIC CONTROLS**

Electrical controls are required on all units which have pumps, electric heat or steam heat. Models equipped with optional Superflo pump assemblies come equipped with a manual motor starter and thermal overload protection. Electrically heated models are equipped with from one to four stainless steel 4.5 KW electric, immersion-type heaters, a thermostat and contactor. Refer to Table 4 for the amperage requirements of Liftkleen Electric Heaters and Pump Motors.

Insulation is added to the tank sides and top on all heated models. This insulation consists of one inch thick polyurethane foam.

INSTALLATION

• SERVICE HOOK-UP

AIR

Units are supplied with a Lockable Air Switch connection. Connect an air supply line to the inlet of the master on/off valve located on the side of the machine (see Figure 14). The recommended air piping arrangement should be followed to assure trouble-free operation (see Figure 15). Once your line is connected, make sure the air switch sleeve is fully engaged to ensure proper air supply.

Note: The minimum operating air pressure is 85 PSI, however, operating at this pressure greatly reduces the lift capacity of the unit. We recommend operating the unit at 90-100 PSI for optimal performance. Maximum inlet pressure is 110 PSI. A pressure gauge is provided on the filter/regulator/lubricator which is located on the side of the Liftkleen washer next to the Air Switch Connection.

ELECTRIC

- On Liftkleen models with **Superflo Pump Assembly** only, a junction box is provided on the side of the unit for hook-up with the appropriate electrical service.
- On Liftkleen models with **electric heat only**, an electrical enclosure is provided. The attachment points on the contactor are appropriately marked.
- On Liftkleen models with **both Superflo Pump Assembly and electric heat**, an electrical enclosure containing a contactor is provided. Connections on the contactor are appropriately marked.

▲ WARNING

The Liftkleen must be properly grounded.

▲ CAUTION

Check the electrical specifications on the nameplate to assure the proper connections.

On 3 phase models equipped with a Superflo pump, make sure that the motor rotation is correct; that is, counter clockwise when viewed from the top. To reverse rotation, switch any two of the 3 phase leads.

DRAIN – A 1-1/2" NPT female drain is located on the bottom of the tank assembly. A plug is installed at the factory. To make connections to the drain, remove the plug

and install appropriate plumbing. It is suggested that a shut-off valve be installed.

WATER SUPPLY – A 3/4" NPT pipe nipple is furnished at the rear of the Liftkleen as shown on Figure 8. This is intended as a connection to a water source for filling tank or make up supply for heated Liftkleen models.

• FLOOR MOUNTING OF LIFTKLEEN

Four (4) mounting holes for anchoring the Models LKR and LKD Liftkleen to the floor are located in the bottom of the channel weldment assembly at the rear of the machine (see Figures 9a,b). These holes accommodate 1/2" diameter bolts. **The machine must be anchored to the floor at these points.** Failure to adequately anchor the unit will affect its lifting capacity and/or cause structural damage to the machine.

OPERATION

▲ WARNING

Always stand clear of lid. To prevent injury, keep head, hands and body clear of the lid, lift platform and lift mechanism at all times. These units have moving parts, pinch-points and close tolerances. Always stand clear of the lift platform and lid when operating as the lid could unexpectedly open or the platform operate. Keep hands and fingers away from tank when operating platform.

• AGITATING LIFT PLATFORM

To operate the unit, first open the lid. On units equipped with the **pneumatically operated lid**, this is done automatically during the next step. Press the "RESET" button. The platform will rise to the top of the unit and is now ready for loading. Please note, the platform will not rise until the lid is fully open.

Once loaded, rotate the Oscillate Selector Switch to the "ON" position. Press the "START" button. Platform will descend to down position and remain there until lid is closed. Upon lid closure, the platform will begin to oscillate and will continue to do so until the operator depresses the "RESET" button or rotates the Oscillate Selector Switch to the "OFF" position. Be sure to open lid when resetting platform. The platform will not oscillate unless lid is closed. Those units equipped with a pneumatically operated lid will close automatically. If soaking is desired,

rotate the Oscillate Selector Switch to the "OFF" position. Once the "START" button is pressed, the unit will lower and stop in the fully down position and will remain idle until the operator depresses the "RESET" button or rotates the Oscillate Selector Switch to the "ON" position.

- **CYCLE TIMER (OPTIONAL)**

This option allows the operator to set the length of time of the cleaning cycle. To actuate the timer, turn the Timer Selector Switch to the "On" position. Set the timer to the desired cycle time, depress the "Start" button to begin the sequence. The platform will agitate for the preset time after which it will rise along with the lid to an Up/Open position for the start of the next cycle. Turn Timer Selector Switch to the "Off" position when manual operation is desired.

Note: The Cycle Timer is only available on units with automatically operated lids. (LKR & LKD units)

- **EMERGENCY STOP**

The unit includes an E-Stop feature which will shut down all pneumatic operation when depressed and should be used in emergency situations only. Once the obstruction/problem is corrected the switch can be reset by simply lifting the button back into its original position.

- **ANTI-TIE DOWN DEVICE (OPTIONAL)**

This device protects the operator from potential situations where contact with a pinch point on the machine can occur. The function of this device replaces the "START" button in the preceding sequence instructions and will require the operator to depress two buttons simultaneously and hold them until the lid is resting in the closed position. The unit will then function normally as described in the previous operational instructions.

- **SUPERFLO PUMP (OPTIONAL)**

A manual starter is provided to enable the operator to turn the pump on when pump agitation is desired. If the optional filtration system is selected, the pump must be operated to create the filtration process. The general arrangement of a pump assembly is shown in Figure 16. For wiring schematic, see Figure 3.

- **ELECTRIC HEAT (OPTIONAL, AQUEOUS UNITS ONLY)**

Heaters are automatically turned on and off by the thermostat (Figure 11) to maintain the desired tank temperature. The thermostat is adjusted by rotating the dial over its indicated range of 60°F to 180°F. The heaters can be shut off by setting the thermostat to the "Off" position. Figure 12 contains data regarding heat-up time for the various Liftkleen models. For wiring schematic, see Figure 3.

Operating temperature should not exceed 180°F.

Note: Never operate heaters unless they are completely covered by liquid.

- **STEAM HEAT (OPTIONAL)**

Liftkleens are available with optional steam heat. This option comes complete with a thermostat and all necessary plumbing and requires the hook-up of the steam supply and condensate lines along with the connection of a 115V electrical supply to the thermostat.

- **HEATER TIMER (OPTIONAL)**

The LKT-1 Heater Timer is available on all heated Liftkleen units. This option allows the operator to preset both the heater startup time and the length of time the heater is in operation each day. The timer also features a "day skipper" feature which allows the unit to remain off on weekends, lowering heating costs.

- **LIFTKLEEN FILTRATION SYSTEMS (OPTIONAL)**

Filtration systems are available on all Liftkleen models featuring pump agitation. The system consists of standard, single or dual filters and a selection of filter elements.

Model LKF-100 (Figure 20) is a single cartridge filter. Model LKF-22 (Figure 21) is a dual cartridge unit. Model LKF-100 is equipped with a 100 mesh (150 micron) Cylinder Strainer Cartridge. This filter cartridge is made of stainless steel, with fine wire mesh reinforced with perforated metal. The LKF-200 dual filter unit is complete with a primary 30 mesh (590 micron) cartridge cylinder and a 100 mesh (150 micron) secondary cartridge cylinder. Cartridges listed in Table 5 may be interchanged with standard ones.

- **LIFT PLATFORM MOTION ADJUSTMENTS**

Liftkleen models are furnished with an **Agitating Lift Platform** and are provided with adjustments for the lift platform speed and agitation frequency. The speed of the lift platform movement can be varied by adjusting the speed control mufflers as follows:

▲ CAUTION

When turning air on or off or when operating the lift platform, stay clear of the lid, lift platform and operating mechanism as the lid could unexpectedly open or the platform operate.

- (1) Activate the operation by setting the selector switch to the "ON" position and depressing the "Start" button.
- (2) Adjust speed control mufflers until desired platform motion is obtained.

The frequency of agitation is dependent on load, e.g. heavy loads will **decrease** frequency while light loads will **increase** frequency.

- **SUPERFLO PUMP DISCHARGE DIRECTION ADJUSTMENT**

On Liftkleen models furnished with the optional Superflo Pump unit, the discharge nozzle from the pump (shown on Figure 17) can be adjusted to provide various liquid motions. The nozzle is set at the factory to provide maximum turbulence - a combination of horizontal and vertical fluid movement. To obtain primarily horizontal movement of the fluid, loosen locking set screw and rotate the nozzle so that its discharge is parallel to the back of the tank and the bottom.

▲ CAUTION

Never direct the discharge upward as splashing could occur which would create a potential hazard.

MAINTENANCE

▲ WARNING

Follow all Lock Out procedures before performing any service or maintenance.

LOCK OUT PROCEDURES

- When performing any maintenance tasks on the Liftkleen be sure that the master on/off air line valve is in the "OFF" position (see Figure 14).
- Disconnect the main air supply to the rack and/or lid cylinders to remove residual air pressure.
- Also, turn electric power to machine "OFF" at main disconnect.

LUBRICATION

- Lubricate the lift channels or roller track (Figure 18) with machinery grade grease. It is recommended that this lubrication be done at least every month.
- Lubricate the lid hinges (Figure 18) by oiling with light machinery oil (SAE 30W or equivalent). This should be done every month. This includes the lid hinges and the lid opening mechanism. Entire lid mechanism should be inspected for wear, especially hinges and bolt attaching lift to cover.

PNEUMATIC SYSTEM

- The filter/regulator/lubricator unit on the side of unit (shown on Figure 14) must be checked at least weekly. **The moisture in the filter bowl is drained by opening the drain valve at the bottom of the unit.** This is especially important during hot weather and may require more frequent attention.

The lubricator must be filled as required with SAE 10W oil or its equivalent and set approximately at 3 drops per minute. The pressure regulator is adjustable between 60-110 PSI. Remember, the unit's lifting capacity changes as the air pressure goes up and down. Recommended pressure is 90 - 100 PSI.

TROUBLESHOOTING GUIDE

ELECTRICAL

CONDITION	POSSIBLE CAUSE	CORRECTION
Pump does not run.	Electrical service to motor is not correct.	Check electrical supply and correct.
	Motor is burned out.	Replace motor or return pump to factory for repair.
Pump runs but does not agitate.	Pump rotation is incorrect (3 Phase Power).	Reverse any two electrical supply lines to motor. (Correct rotation is CCW - see label.)
Pump runs but is noisy. (Minor sound created by liquid flow through pump is normal.)	Cavitation due to low liquid level.	Raise liquid to correct level.
Tank does not reach operating temperature.	Electrical supply is not on.	Check and correct electric service.
	Thermostat is set too low.	Raise thermostat temperature.
	Faulty heater.	Check and replace if necessary.
	Heating contactor is faulty.	Check and replace if necessary.
Tank takes too long to heat up. (See Figure 12 for heat-up times).	Electrical supply voltage is incorrect.	Check and correct if necessary.
	One element of the tri-element heater is burned out.	Check heater elements and replace heater if necessary.
	Excessive heat loss due to open lid.	Lower rack and lid when unit is not in use.
Heater Timer		
Tank does not reach operating temperature.	115V, Single phase power supply off.	Turn on.
	Timer actuating tripper not attached.	Attach tripper.
	Timer actuating tripper incorrectly positioned.	Position correctly.
	Faulty timer.	Replace.
	Faulty transformer.	Replace.
	Faulty contactor.	Replace.

CONDITION	POSSIBLE CAUSE	CORRECTION
Cycle Timer		
Platform oscillates but does not raise automatically after cycle.	Lid cylinder fails to operate.	Check and manually activate.
	Solenoid valve stuck. (Only on LKT-3)	Clean or replace.
	Solenoid inoperative.	Replace after checking electrical characteristics.
Platform does not agitate.	Solenoid valve stuck. (Only on LKT-3)	Clean or replace.
	Solenoid inoperative. (Only on LKT-3)	Replace after checking electrical characteristics.
	Faulty air valve.	Replace.
	Faulty timer.	Replace.
PNEUMATIC		
Lift platform is jammed.	Parts lodged in lifter mechanism.	Reverse unit and remove parts.
Platform does not operate properly.	Air supply is not connected.	Check and connect air supply.
	Master on/off valve is in "OFF" position.	Turn to "ON" position.
	Main air pressure regulator set too low.	Adjust regulator to 80 psi minimum.
	Speed control mufflers adjusted incorrectly.	Correct adjustment.
	Pneumatic air control supply line pinched or disconnected.	Check and repair as required.

CONDITION	POSSIBLE CAUSE	CORRECTION
No action when selector switch is moved.	Air supply off.	Check and turn on.
	Pneumatic air control lines pinched or disconnected.	Check and repair as required.
	Air pressure at incorrect setting.	Check and adjust to 80 psi on supply.
	Faulty selector switch.	Replace switch.
	Speed control mufflers adjusted incorrectly.	Correct adjustment.
	Sticking power valve due to condensation, etc.	Disconnect all lines to cylinder and cycle unit. Reconnect cylinder.
Platform raises to "Up" position even though control selector knob is set at another position.	Air supply line to control box is cut, pinched, or shut off.	Check and correct.
Platform will not move from "Up" position.	Air supply line to control box is cut, pinched, or shut off.	Check and correct.
Lid does not open.	Air supply to lid control too low or off. Speed control improperly adjusted.	Check for 80 psi minimum air pressure.
Lid <u>opens</u> too fast or too slowly.	Speed control improperly adjusted.	Adjust – turn adjusting screws in to slow opening, out to speed up.
Lid <u>closes</u> too fast or too slowly.	Same as above.	Same as above.

TABLE 1
DIMENSIONS/SPECIFICATIONS

		MODELS*				
		SERIES	SERIES	SERIES	SERIES	SERIES
		LKR36	LKR48	LKR60	LKD60	LKD72
DIPPING SPACE	Length A	38½"	50½"	62½"	62½"	74½"
	Width B	28"	40"	40"	40"	46"
	Depth C	20"	20"	20"	30"	30"
LIFT PLATFORM**	Length D	36"	48"	60"	60"	72"
	Width E	24"	36"	36"	36"	42"
	Weight Capacity**	550 lbs. (100 PSI)	450 lbs. (100 PSI)	700 lbs. (100 PSI)	700 lbs. (100 PSI)	700 lbs. (100 PSI)
TANK INSIDE (Does not include pump compartment)	Length F	40"	52"	64"	64"	76"
	Width G	34½"	46½"	46½"	46½"	52½"
	Depth H	35"	35"	35"	45"	45"
TANK OUTSIDE	Length J	42½"	54½"	66½"	66½"	78½"
	Width K	45"	57"	57"	57"	63"
	Height L	41"	41"	41"	50¾"	50¾"
OVERALL MACHINE	Length M	54½"	66½"	78½"	78½"	90½"
	Width N	45"	57"	57"	57"	63"
	Height P	76"	76"	76"	96"	96"
TOTAL LIQUID DEPTH	R	27"	27"	27"	37"	37"
LIQUID CAPACITY (gallons)		170	290	355	491	667
SERVICE CONNECTIONS						
AIR INLET		3/8" NPT	3/8" NPT	3/8" NPT	1/4" NPT	1/4" NPT
WATER INLET		3/4" NPT	3/4" NPT	3/4" NPT	3/4" NPT	3/4" NPT
DRAIN		2" NPT	2" NPT	2" NPT	2" NPT	2" NPT
OVERFLOW OUTLET		3/4" NPT	3/4" NPT	3/4" NPT	3/4" NPT	NONE
THERMOSTAT RANGE		60°-180°F	60°-180°F	60°-180°F	60°-180°F	60°-180°F
ELECTRIC HEATERS (optional)****		4.5 KW	4.5 KW	4.5 KW	4.5 KW	4.5 KW
INSULATION (sides and cover)						
WHEN HEATED		Polystyrene Foam - 1" Thick				
AGITATION DATA						
All Liftkleen parts cleaning machines feature up and down agitation of the lift platform. The length of stroke can be manually adjusted.						
STROKE LENGTH (variable)		3"-5"	3"-5"	3"-5"	3"-5"	3"-5"
NUMBER OF STROKES (per minute)		25-40	25-40	25-40	25-40	25-40
PUMP AGITATION (optional)						
PUMP HORSEPOWER		1½	1½	1½	1½	1½ (2 pumps)
GALLONS PER HOUR		10,000	10,000	10,000	10,000	20,000
VOLTAGE, HERTZ, PHASE		230/460,60	230/460,60	230/460,60	230/460,60	230/460,60
(same as heaters)		1 or 3 PH	1 or 3 PH	1 or 3 PH	1 or 3 PH	1 or 3 PH

PARTS BASKETS

Length/Width/Depth/Overall Height

CONSULT FACTORY

* All LIFTKLEEN models available heated or unheated.

** Rollers in place of grate optional.

*** Greater lifting capacity available.

**** Standard LIFTKLEEN heating is designed for minimum power draw. For quicker heat-up additional heaters are available.

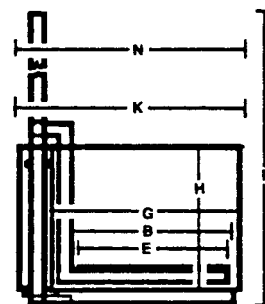
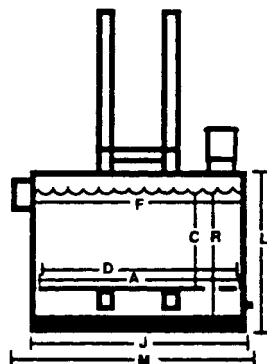

TABLE 2**PLATFORM LOAD CAPACITY**

LIFTKLEEN BASIC MODEL	CYL. DIA.	WORKING LOAD AT VARIOUS AIR PRESSURES				
		70 PSI	80 PSI	90 PSI	100 PSI	110 PSI
LKR 36	4"	330	400	480	550	630
LKR 36 <u>IL</u>	5"	425	740	860	980	*___
LKR 48	4"	230	300	380	450	530
LKR 48 <u>IL</u>	5"	525	640	760	880	990
LKR 60	5"	325	440	560	680	790
LKR 60 <u>IL</u>	5" (2)	1150	1385	1620	1850	*2090
LKD 60	5"	325	440	560	680	790
LKD 60 <u>IL</u>	5" (2)	1150	1385	1620	1850	*2090
LKD 72 <u>IL</u>	5" (2)	1050	1285	1520	1750	1990

IL = Increased Lift Capacity because of larger cylinder.

*___ Exceeds rated capacity.

NOTE: The above working loads are calculated at 60% of gross cylinder capacity less rack weight. This is required for good agitation.

Average agitation cycle (up and down) will be approximately 30 per minute. This will vary with the load, air pressure and volume.

Pump agitation is continuous regardless of load.

TABLE 3**AIR CONSUMPTION
(5 IN. STROKE)**

CYLINDER SIZE (IN.)	MODELS	STROKES PER MINUTE	"UP" ONLY (SCFM)			"UP" AND "DOWN" (SCFM)		
			60 PSI	80 PSI	100 PSI	60 PSI	80 PSI	100 PSI
4	LKR-36, -48	20	5.4	6.9	8.4	8.7	10.8	13.0
5	LKR-36, -48(Heavy) LKR-60 LKD-60, -72	20	8.5	10.8	13.2	13.6	17.1	20.5
5 (2)	LKR-60 LKD-60, -72 (Heavy Lift)	20	17.2	21.9	26.5	27.5	34.5	41.3
4	LKR-36, -48	40	7.2	9.2	11.2	11.6	14.4	17.4
5	LKR-36, -48(Heavy) LKR-60 LKD-60, -72	40	11.4	14.4	17.6	18.2	22.8	27.4
5 (2)	LKR-60 LKD-60, -72 (Heavy Lift)	40	23.8	29.2	35.4	36.8	46.0	55.2

TABLE 4
ELECTRICAL CURRENT REQUIREMENTS

VOLTAGE/PHASE	HEATER AMPERAGE		
	1 Heater (4500 W)	2 Heaters (9000 W)	3 Heaters (13,500 W)
240 V/1-Ph	18.8	37.5	56.3
240 V/3-Ph	10.8	21.7	32.5
480 V/3-Ph	5.4	10.8	16.2
575 V/3-Ph	4.5	9.0	13.5

Note: Add the corresponding motor amps below to the above heater amps to find the full load amperage.

VOLTAGE/PHASE	MOTOR AMPERAGE (1-1/2 H.P., 1725 RPM)
230 V/1-Ph	10.5
230 V/3-Ph	4.6
460 V/3-Ph	2.3
575 V/3-Ph	2.0

TABLE 5
FILTERS

Filter Housing #742-06154 is used with the following cartridge assemblies.

Cartridge #	Cartridge Type	Particle Retention Size	Element Number
742-06317	Stacked Disc	3-5 Micron	742-06318
742-06319	Disposable Bag	50 Micron	742-06320
742-06332	Strainer	590 Micron (30 Mesh)	742-06331
742-06243	Strainer	150 Micron (100 Mesh)	742-06244
—	Strainer*	100 Micron (150 Mesh)	742-06379
—	Strainer*	74 Micron (200 Mesh)	742-06380
—	Strainer *	30 Micron (2140 Mesh)	742-06381

*These are optional elements (not cartridge assemblies). They can be used in place of the standard elements (30 Mesh and 100 Mesh) in cartridge assemblies #742-06332 and 742-06243.

REPLACEMENT PARTS

PNEUMATIC SYSTEM COMPONENTS

PART NO.	DESCRIPTION
LKR/LKD COLD AND HEATED UNITS	
738-90652	Emergency Stop button
738-90664	3-Way Valve, green
738-90637	3-Way Valve, black
738-90638	3-Way Switch
738-90642	4-Way Pilot Valve
738-90641	3-Way Valve
738-90843	Limit Valve
738-90844	Limit Valve Roller Arm Only
738-90672	Manifold Valve
738-90643	Pressure Pilot Valve, 3-Way
738-90639	Pressure Pilot Valve, 4-Way
738-90640	Impulse Relay Valve
738-90649	Valve
746-06130	Air Filter Regulator Lubricator Kit
738-90688*	Speed Control Elbow Valve
746-06496	Speed Control Muffler, 1/2" NPT
451-24446‡	Safety Link Assembly
738-90777	4-Way Valve / 2 positions
738-90848	Pilot Operated Check
746-06209	Speed Control Muffler 1/4 NPT
746-06904	Muffler 1/8 NPT

ELECTRICAL & HEATING SYSTEM

PART NO.	DESCRIPTION
IMMERSION TYPE HEATERS, 4.5 KW	
780-06112	240 V, 1-Ph, 60/50 Hz (B)
780-06077	240 V, 3-Ph, 60/50 Hz (J)
780-06080	480 V, 3-Ph, 60/50 Hz (Y)
780-06164	575 V, 3-Ph, 60/50 Hz (Z)
781-06081-81	Protective Well
780-06079	Thermostat
780-06364	Control Transformer
MOTOR PROTECTION COIL (HEATERS)	
780-06250	240 V, 1-Ph, 60 Hz
780-06246	240 V, 3-Ph, 60 Hz
780-06247	480 V, 3-Ph, 60 Hz
780-06248	575 V, 3-Ph, 60/50 Hz

PART NO.	DESCRIPTION
CYCLE TIMER COMPONENTS (LKT-4)	
780-90650	Timer
738-90638	3-Way Switch
738-90642	4-Way Pilot Valve
738-90649	Valve
ANTI-TIE DOWN COMPONENTS (LKT-AT)	
746-90655	Anti-Tie Down, two hand control
738-90640	Impulse Relay Valve
738-90649	Valve
738-90847	3-Way Pilot Valve

* Not on manual lid models

‡Cold units only

PART NO.	DESCRIPTION
MAGNETIC CONTACTOR	
780-06078	240/480/575 V
MANUAL STARTER	
780-06245	1- and 3-Phase
746-06237	Thermometer 3" Dial
780-06148	7-Day Heating Timer (LKT-1)
MOTORS, LKR/D 1½ HP	
370-06061	230V, 1 Ph, 60 Hz (B)
370-03918	230/460 V, 3 Ph, 60/50 Hz (J) or (Y)
370-06149	575V, 3 Ph, 60 Hz (Z)

PUMP ASSEMBLY REPLACEMENT PARTS

See Figure 16 for diagram

PART NO.	DESCRIPTION
1	Motor
2	661-16442 Vapor Screen
3	532-12960 Vapor Diffuser
4	744-15258 Gasket
5	724-05658 Pipe Plug, 3/4 NPT
6	753-02679 Set Screw
7	432-16608 Nozzle
8	602-18496 Reducing Tee
9	720-04148 Nipple
10	752-02971-12 Screw
11	528-16563 Bearing Retainer
12	744-15671 Slinger
13	646-23152-81 Pump Mounting Lid
14	752-02913-12 Screw
15	753-00817 Set Screw
16	573-13728-08 Coupling
17	438-23841-S Column Assembly
18	561-25950-63 Shaft
19	765-04108-81 Spring
20	752-07862-12 Screw
21	754-03510-18 Flat Washer
22	525-16258-74 Impeller
23	517-23427 Upper Volute
24	744-15498 Volute Gasket
25	518-16755 Lower Volute
26	752-03935-12 Screw
27	543-16580-74 Castle Nut
28	756-00893-81 Cotter Pin
29	754-18294-88 Drive Washer
30	760-06508 Bushing
31	760-18308 Sleeve

AIR CYLINDERS

CYC. NO.	APPLICATION	CYL. SIZE
746-90804	Pneumatic Lid Lift	2½"Øx23" STR
746-90807	LKR-36	4"Øx29" STR
746-90805	LKR 36 Increased Lift	5"Øx29" STK
746-90807	LKR 48	4"Øx29" STK
746-90805	LKR 48 Increased Lift	5"Øx29" STK
746-90805	LKR 60	5"Øx29" STK
746-90805	LKR 60 Increased Lift	(2)5"Øx29" STK
746-90806	LKD 60	5"Øx39" STK
746-90806	LKD 60 Increased Lift	(2)5"Øx39" STK
746-90806	LKD 72	5"Øx39" STK
746-90806	LKD 72 Increased Lift	(2)5"Øx39" STK

MISCELLANEOUS MECHANICAL PARTS

PART NO.	DESCRIPTION
459-23982	Roller Assembly (includes bearings) for LKR & LKD

FIGURE 1
BASIC ASSEMBLY LKR & LKD

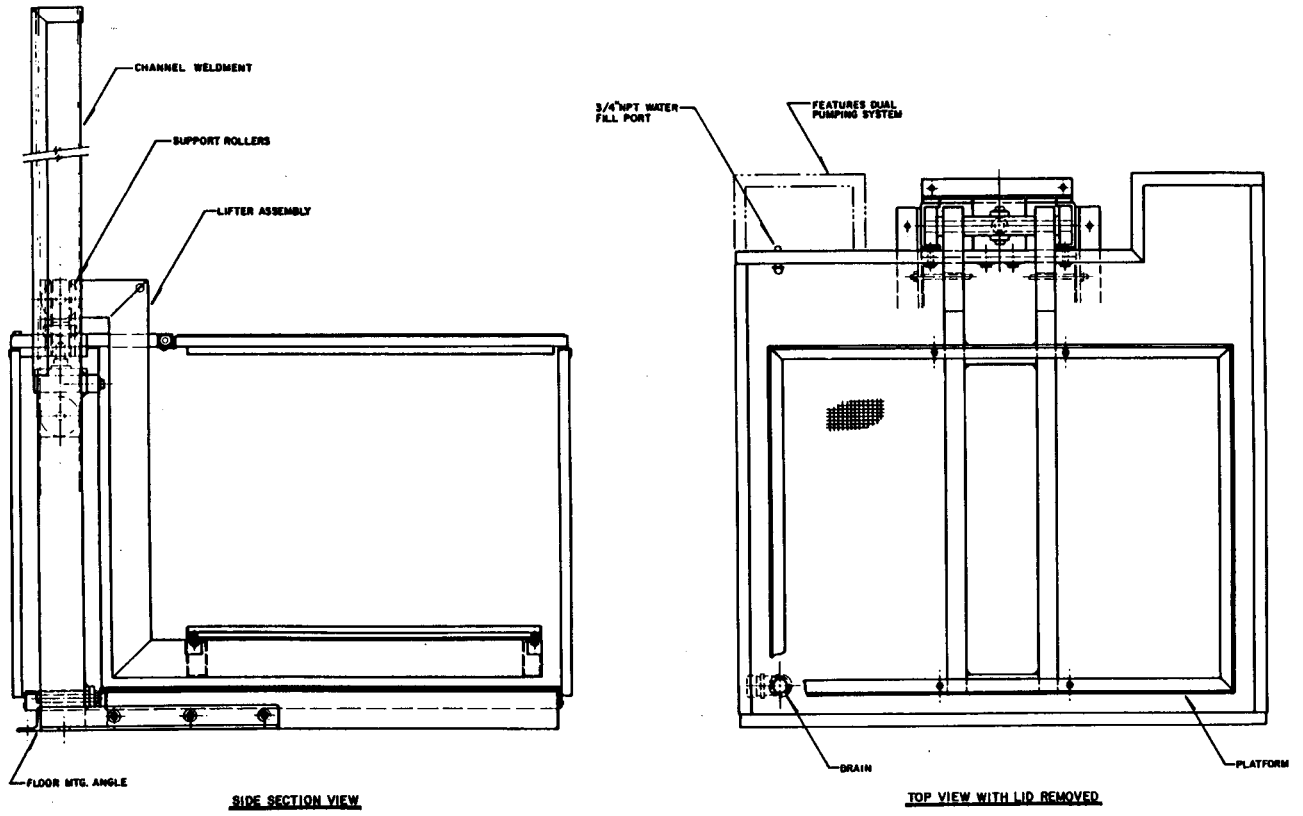

FIGURE 2
BASIC ASSEMBLY LKR & LKD

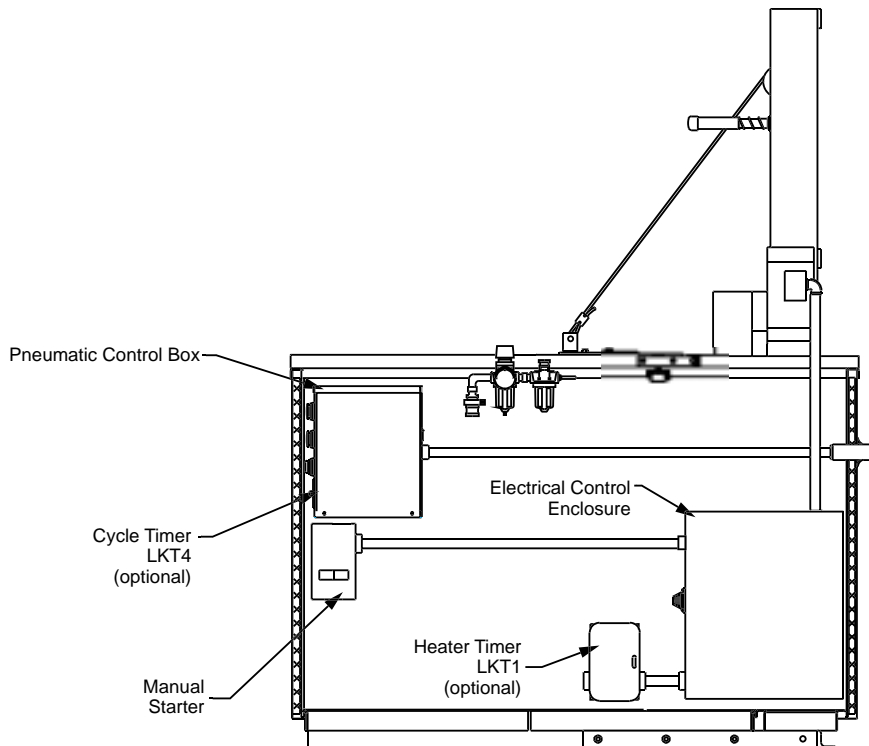
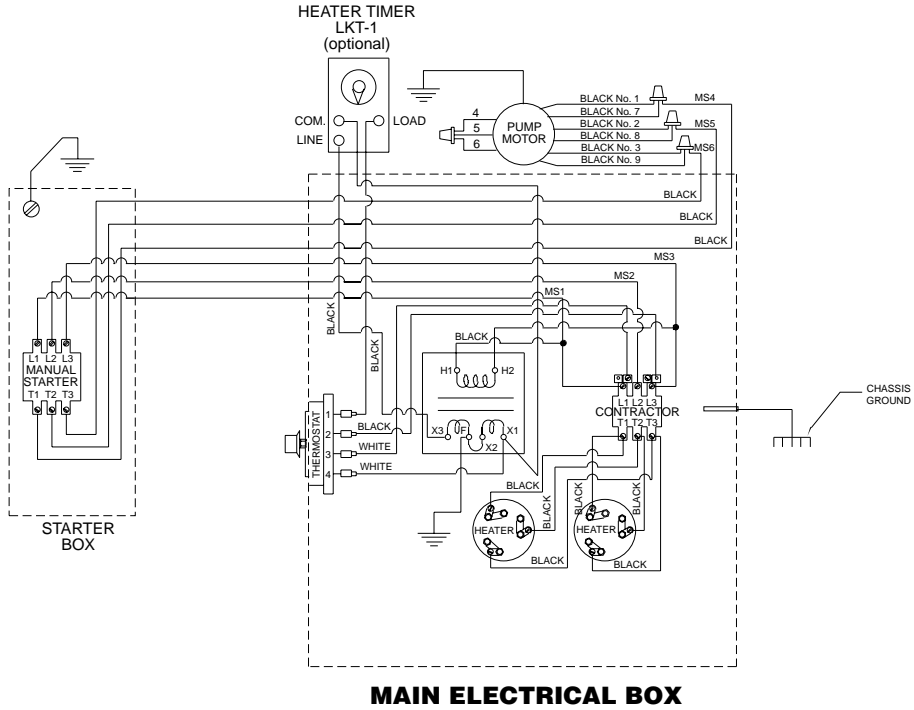

FIGURE 3

ELECTRICAL SCHEMATIC - 3 PHASE



ELECTRICAL SCHEMATIC - 1 PHASE

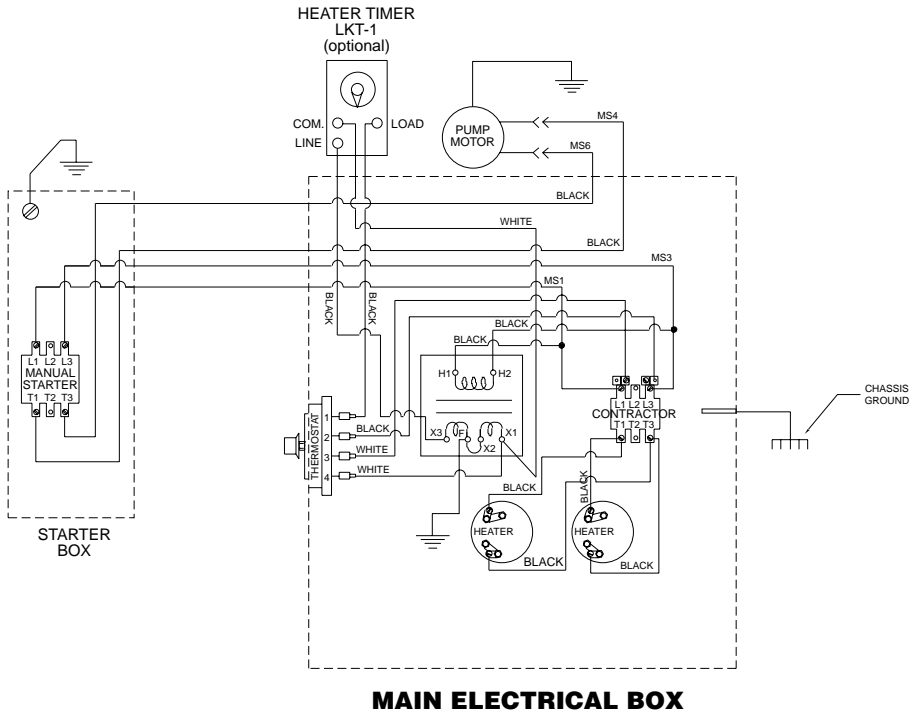

FIGURE 4a

PNEUMATIC SYSTEMS

APPLICATION: Hot units with manual lid

DESCRIPTION: Pneumatic system consisting of:

1. Control box with a 2 position (ON-OFF) Oscillate Selector Switch, Start, Reset, and Emergency Stop Buttons.
2. Mechanical type valves
3. Lid Lockout.

SEQUENCE OF OPERATIONS:

START: Lid Closed, Rack Down

LOADING:

1. Manually open lid
2. Depress Reset button.

AGITATION:

1. Turn Oscillate Selector switch to ON position
2. Depress Start Button
3. Manually close lid

SOAK:

1. Turn Oscillate Selector to OFF position
2. Depress Start button.
3. Manually close lid

LID LOCKOUT: Lid activated switch overrides all other selector switches and prevents rack from going to the UP position before the lid is fully opened.

See Drawing #796PD37643

FIGURE 4b

PNEUMATIC SYSTEMS

APPLICATION: Hot units with pneumatic lid

DESCRIPTION: Pneumatic system consisting of:

1. Control box with a 2 position (ON-OFF) Oscillate Selector Switch, Start, Reset, and Emergency Stop Buttons.
2. Mechanical type valves
3. Lid Lockout.

SEQUENCE OF OPERATIONS:

START: Lid Closed, Rack Down

LOADING:

1. Depress Reset button, lid will close automatically

AGITATION:

1. Turn Oscillate Selector switch to ON position
2. Depress Start Button, lid will close automatically

SOAK:

1. Turn Oscillate Selector to OFF position
2. Depress Start button, lid will close automatically

LID LOCKOUT: Lid activated switch overrides all other selector switches and prevents rack from going to the UP position before the lid is fully opened.

See Drawing #796PD37641

FIGURE 4c

PNEUMATIC SYSTEMS

APPLICATION: Cold units with pneumatic lid

DESCRIPTION: Pneumatic system consisting of:

1. Control box with a 2 position (ON-OFF) Oscillate Selector Switch, Start, Reset, and Emergency Stop Buttons
2. Mechanical type valves
3. Lid Lockout
4. Fire Safety Circuit
5. Pneumatic Lid (required)

SEQUENCE OF OPERATIONS:

START: Lid Closed, Rack Down

LOADING:

1. Depress Reset button, lid will close automatically

AGITATION:

1. Turn Oscillate Selector switch to ON position
2. Depress Start Button, lid will close automatically

SOAK:

1. Turn Oscillate Selector to OFF position
2. Depress Start button, lid will close automatically

LID LOCKOUT: Lid activated switch overrides all other selector switches and prevents rack from going to the UP position before the lid is fully opened.

FIRE SAFETY CIRCUIT: Automatically lowers rack to the bottom of the tank and closes lid in the event of a fire inside the tank and overrides the selector switches and intermediate stop. The safety circuit is activated by a Graymills fusible vent tube which, when it melts, vents a momentary air signal.

See Drawing #796PD37672

FIGURE 4d

ANTI-TIE DOWN SYSTEMS

APPLICATION: All units with Anti-Tie Down devices

DESCRIPTION: Pneumatic system consisting of:

1. Control box with a 2 position (ON-OFF) Oscillate Selector Switch, Start, Reset, and Emergency Stop Buttons.
2. Anti-Tie Down Device
3. Mechanical type valves
4. Lid Lockout

SEQUENCE OF OPERATIONS:

START: Lid Closed, Rack Down

LOADING:

1. Depress both buttons on the Anti-Tie Down device simultaneously and hold until the lid opens completely and the rack is in the fully upright position, then release the Anti-Tie Down buttons

AGITATION:

1. Turn Oscillate Selector switch to ON position
2. Depress both buttons on the Anti-Tie Down device simultaneously and hold until the rack is in the down position and the lid closes completely, then release the Anti-Tie Down buttons

SOAK:

1. Turn Oscillate Selector to OFF position
2. Depress both buttons on the Anti-Tie Down device simultaneously and hold until the rack is in the down position and the lid closes completely, then release the Anti-Tie Down buttons

LID LOCKOUT: Lid activated switch overrides all other selector switches and prevents rack from going to the UP position before the lid is fully opened.

See Drawing #796PD37642-1

FIGURE 5A or 5B

LKT-4 CYCLE TIMER

APPLICATION: All units equipped with LKT-4 Cycle Timer

DESCRIPTION: Pneumatic system consisting of:

1. Control box with a 2 position (ON-OFF) Oscillate Selector Switch, Start, Reset, Emergency Stop Buttons, and a Timer Device.
2. Mechanical type valves
3. Lid Lockout
4. Pneumatic Lid (required)

SEQUENCE OF OPERATIONS:

START: Lid Closed, Rack Down

LOADING:

1. Depress Reset button, lid will open automatically and rack will rise to UP position.

AGITATION:

1. Turn Oscillate Selector switch to ON position
2. Depress Start button, rack will lower to the DOWN position and lid will close automatically, upon closure rack will oscillate until RESET button is depressed

SOAK:

1. Turn Oscillate Selector to OFF position
2. Turn Timer Switch to OFF position
3. Depress Start button, rack will lower to the DOWN position and lid will close automatically.

TIMER:

1. Turn Oscillate Selector to ON position
2. Turn Timer Switch to ON position
3. Set Timer to the desired cycle time
4. Depress Start button, rack will lower to the DOWN position and lid will close automatically. Upon closure, rack will oscillate for set time. Upon completion, lid will open and rack will rise to the UP position.

Please Note: Timer purchased in conjunction with Anti-Tie Down option will function the same except ATD buttons will replace the RESET and START function in the above sequence. The ATD buttons will need to be held until lid makes contact with closure position switch before auto operation will resume. See Figure 4D for further details.

See Drawing #796PD37640 or #796PD37642-2

FIGURE 6
MANUALLY OPENED SPRING
COUNTERBALANCED COVER - STYLE #1

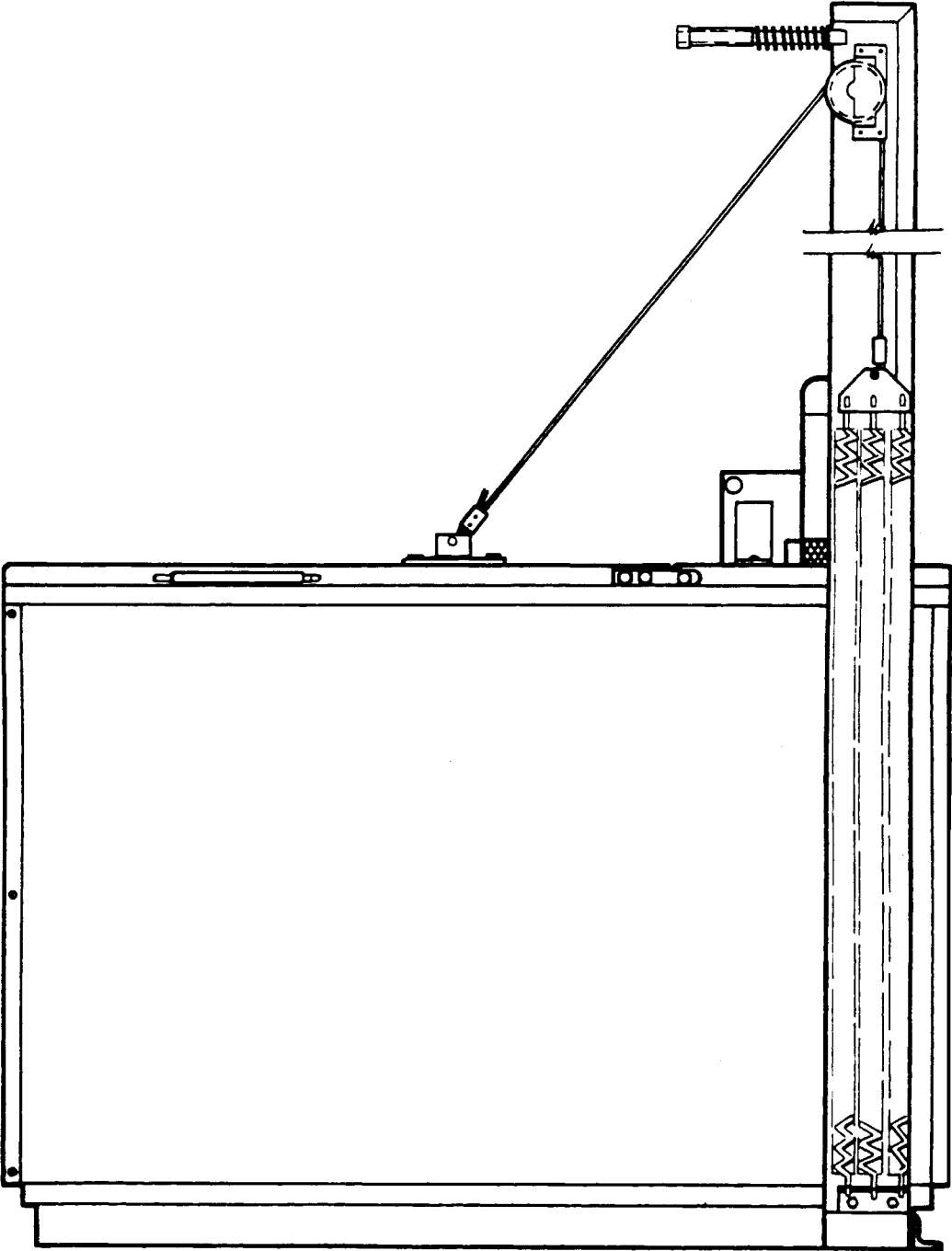

FIGURE 7
CYLINDER OPERATED
COVER OPENING - STYLE #2

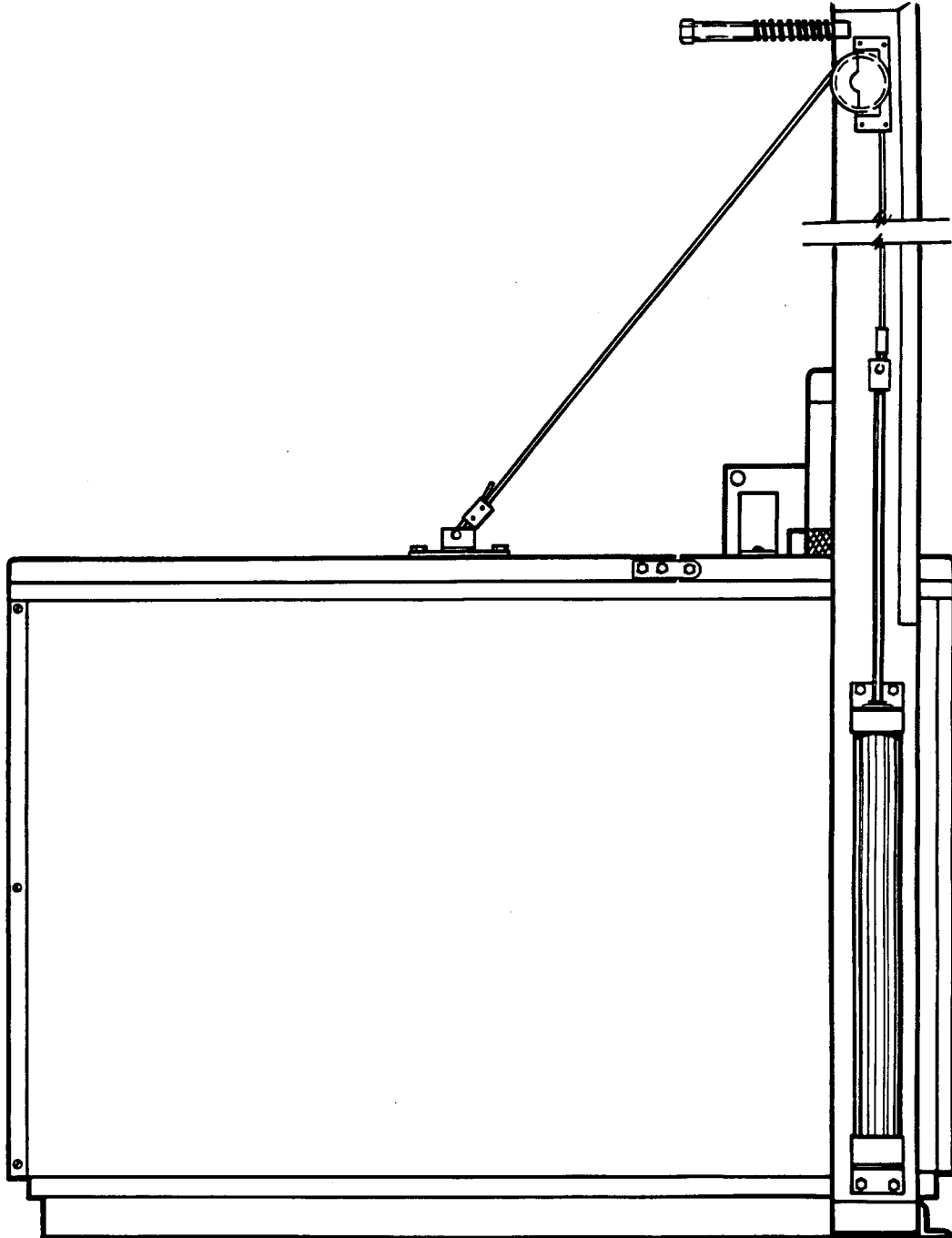
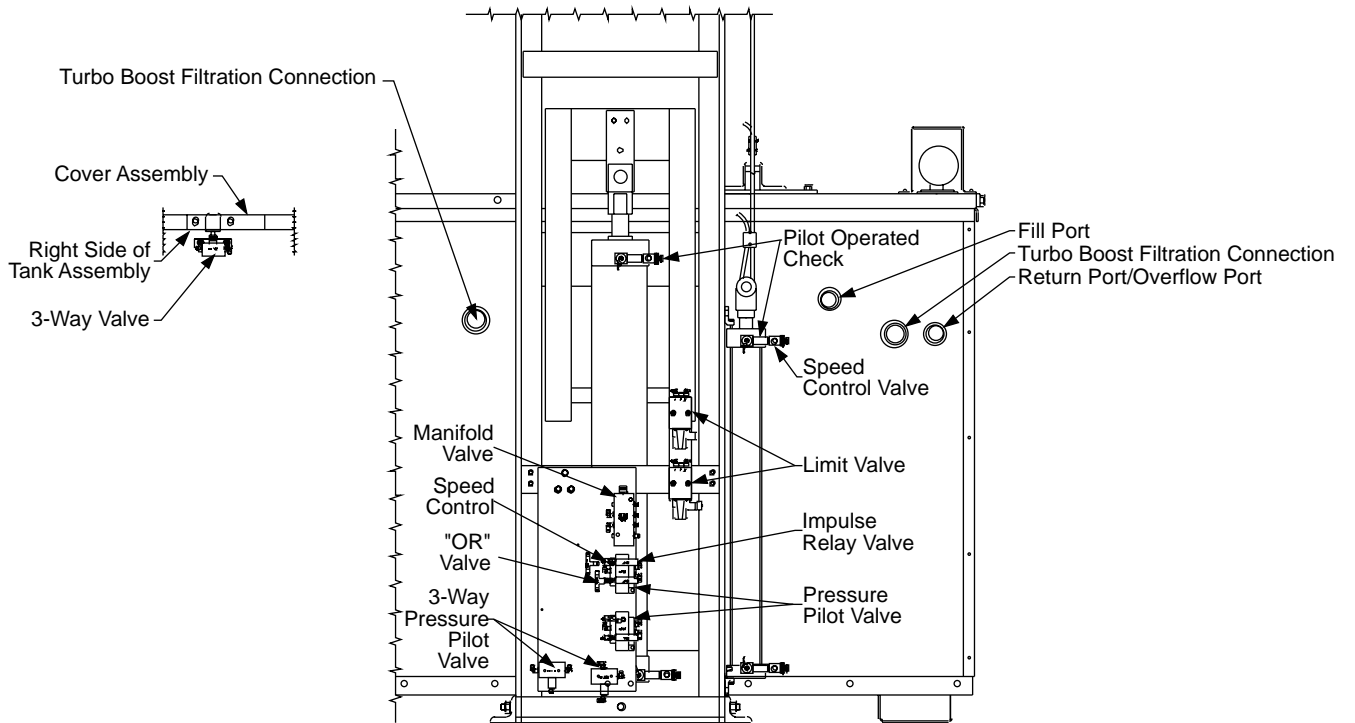

FIGURE 8 VALVE CONNECTIONS

4" CYLINDER



5" CYLINDER

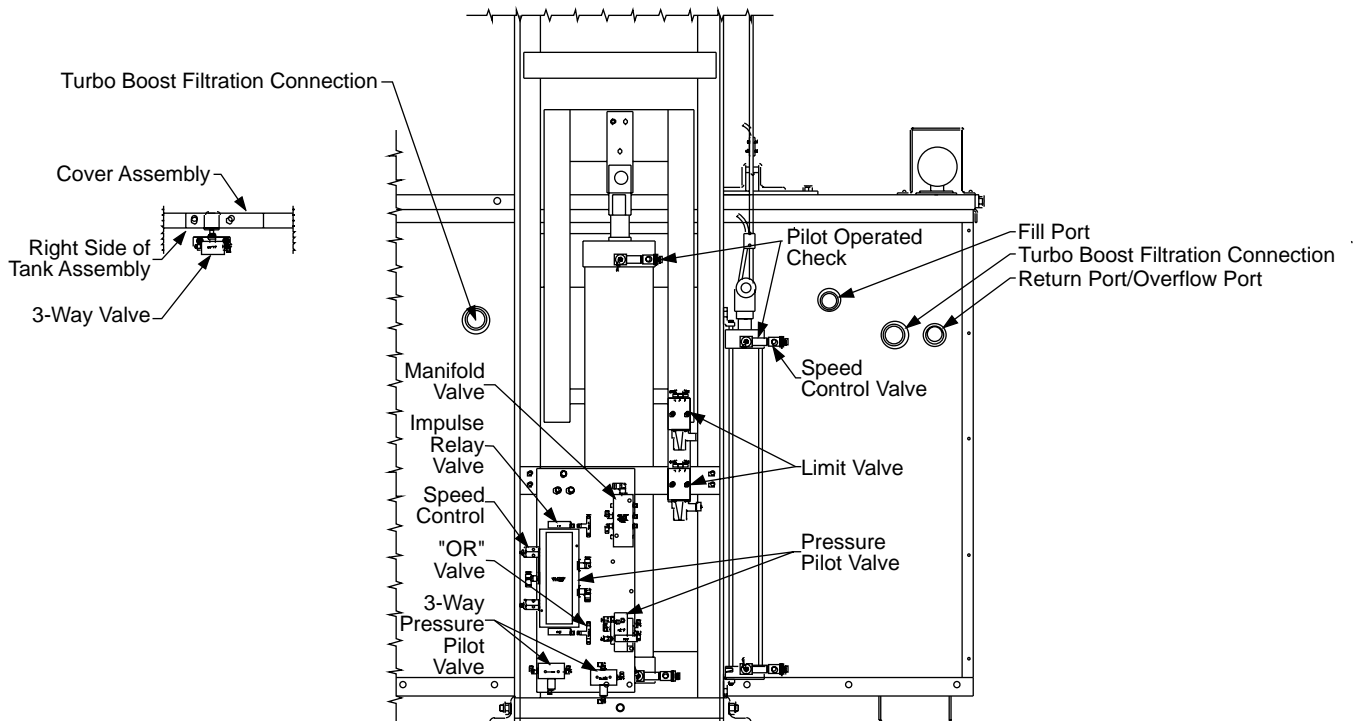

FIGURE 9a

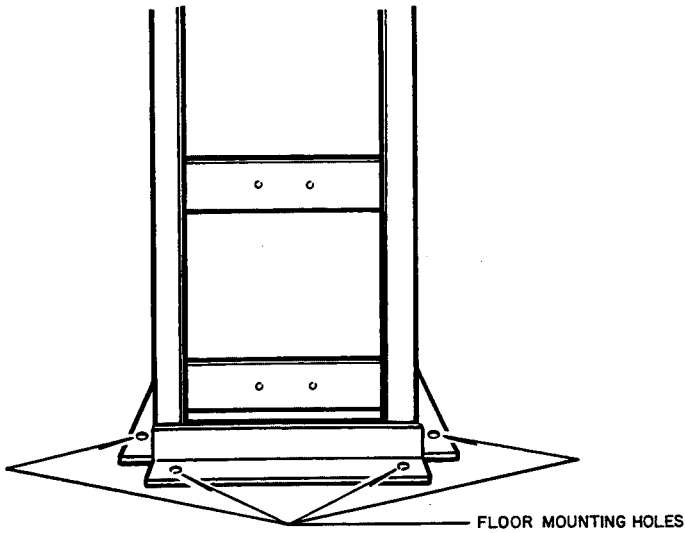
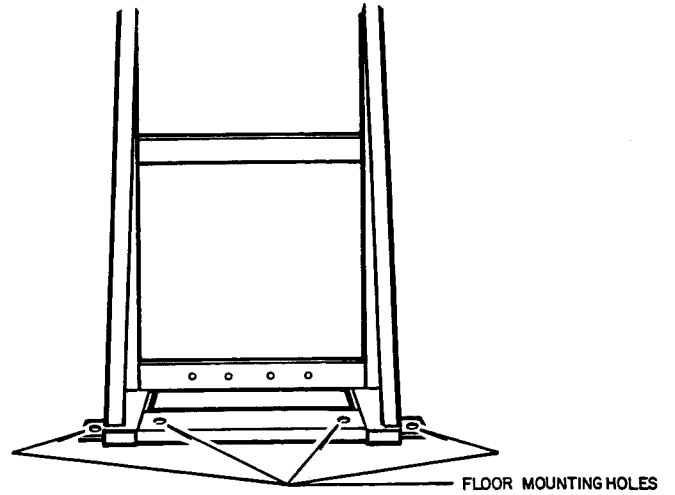
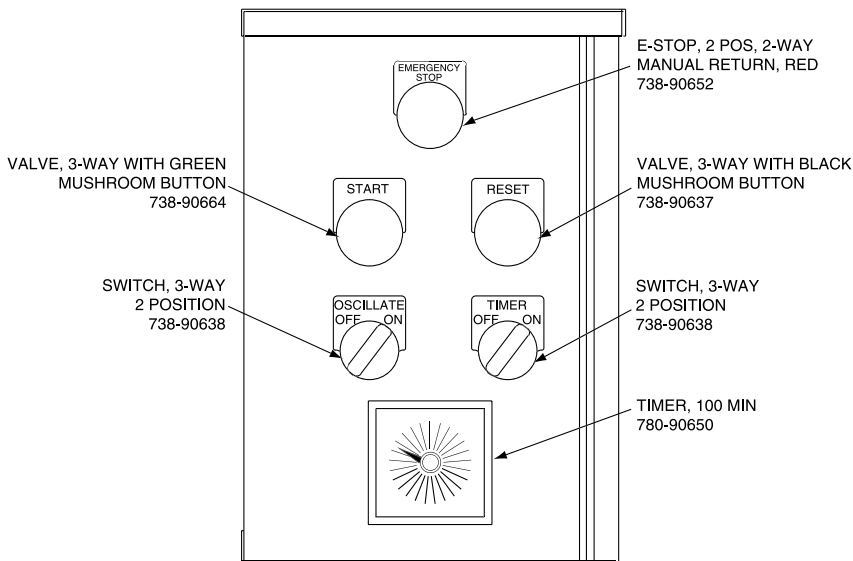

FIGURE 9b



FLOOR MOUNTING HOLE LOCATIONS

FIGURE 10



**LIFTKLEEN OPERATING SWITCH FOR
AGITATED PLATFORM MODELS &
PNEUMATIC LID – STYLE #2**

FIGURE 11

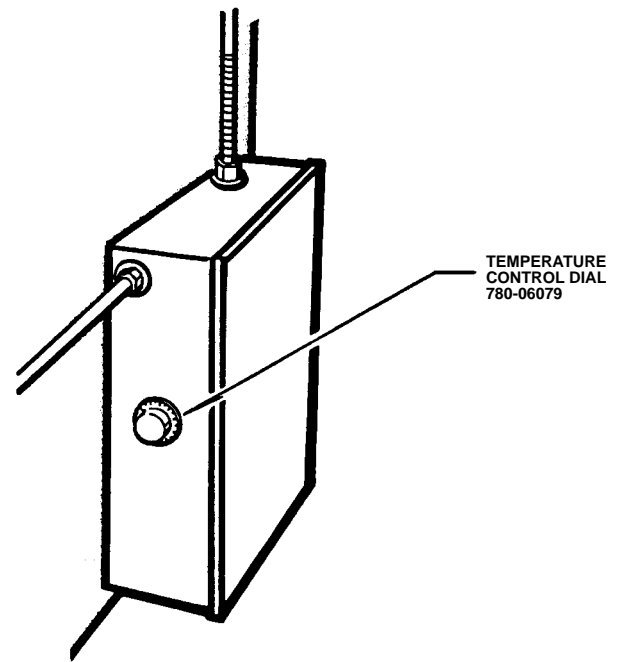

**TEMPERATURE ADJUSTMENT
DIAL**

FIGURE 12
HEATUP TIME

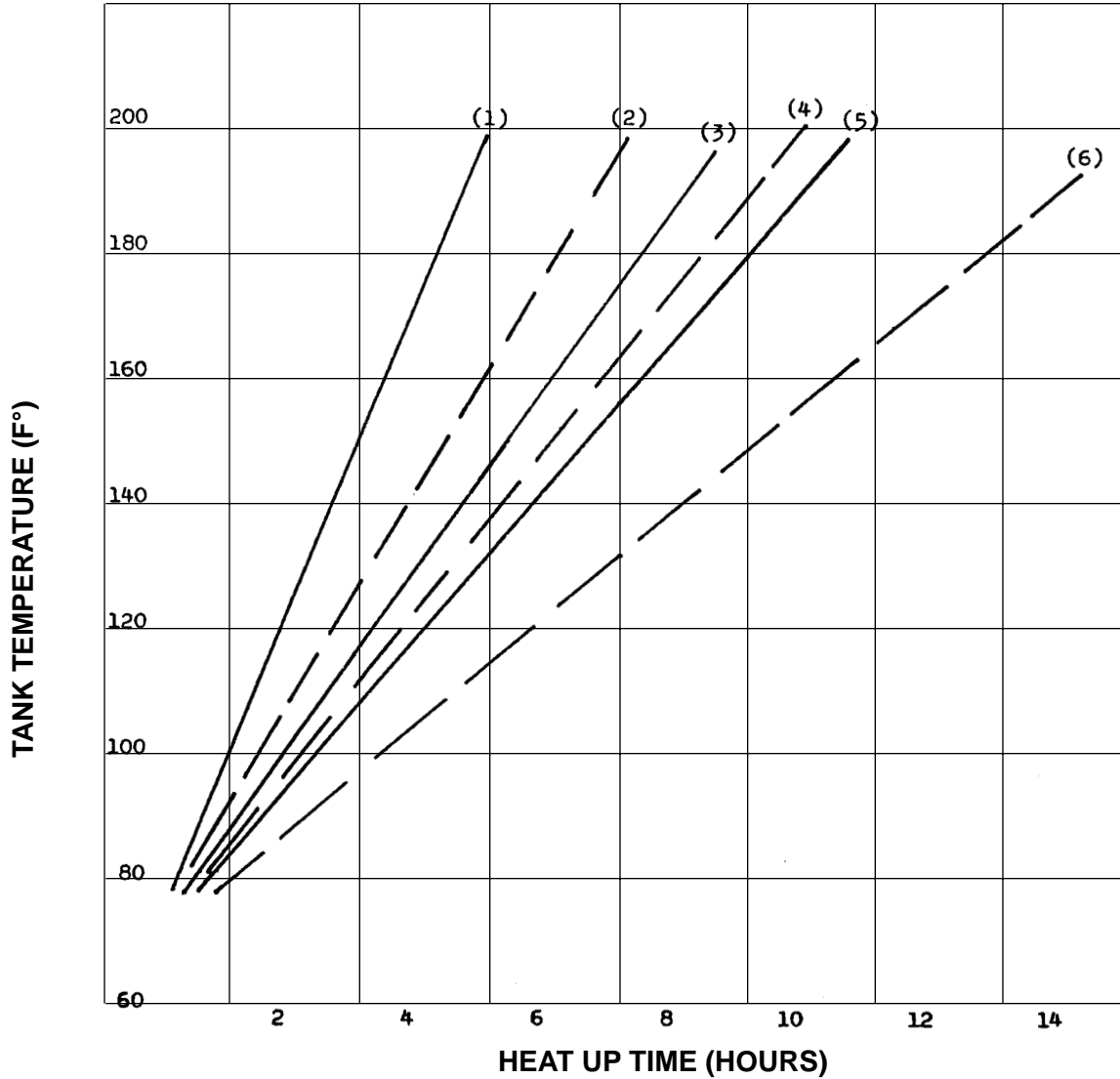

- (1) LKR 36
- (2) LKR 60 (3 Heaters)
- (3) LKR 48
- (4) LKD 60 (3 Heaters)
- (5) LKR 60 (2 Heaters)
- (6) LKD 60 (2 Heaters)

FIGURE 13

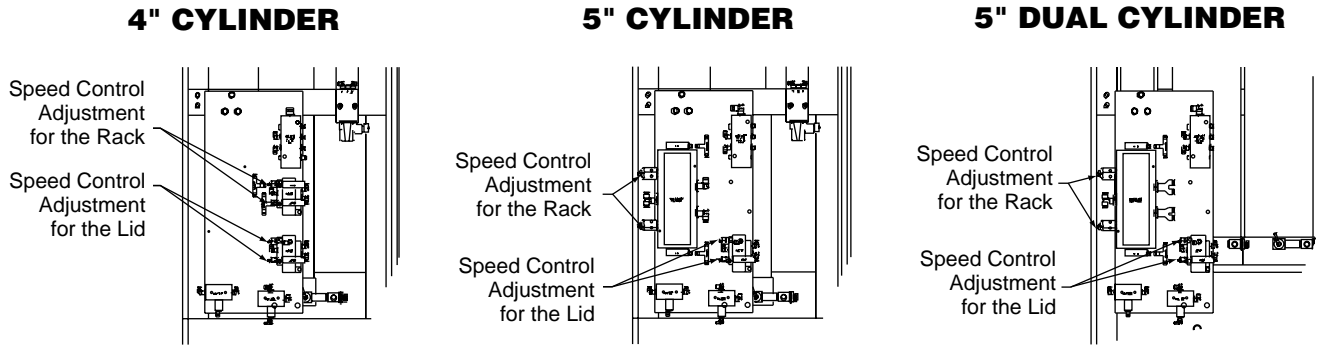

SPEED CONTROLS

FIGURE 14

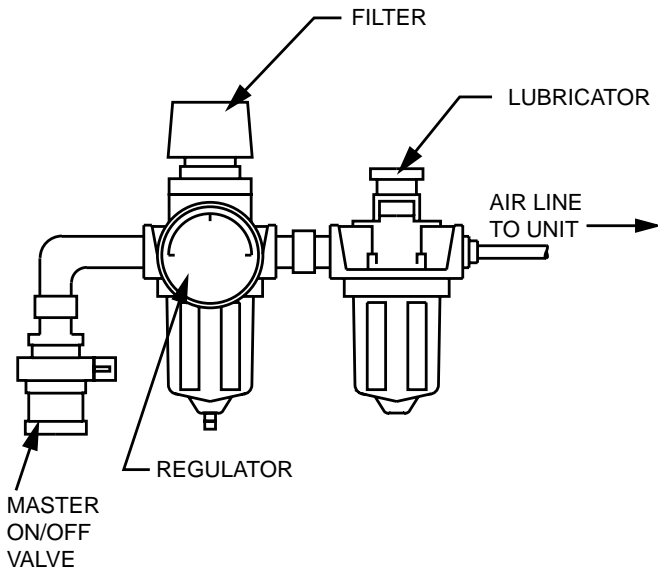

MASTER "ON/OFF" VALVE AND AIR FILTER/REGULATOR/LUBRICATOR

FIGURE 15

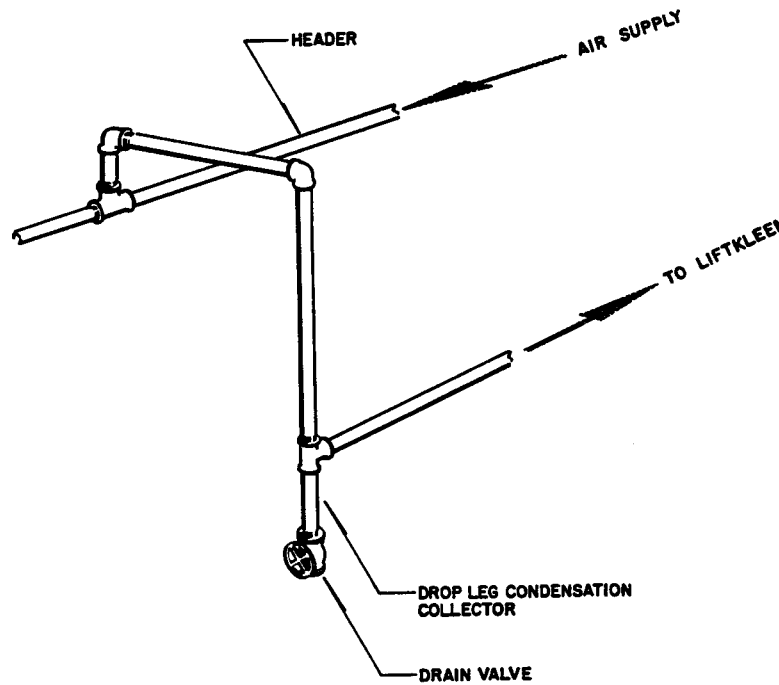

RECOMMENDED AIR LINE CONNECTION TO ALL LIFTKLEEN MODELS

FIGURE 16

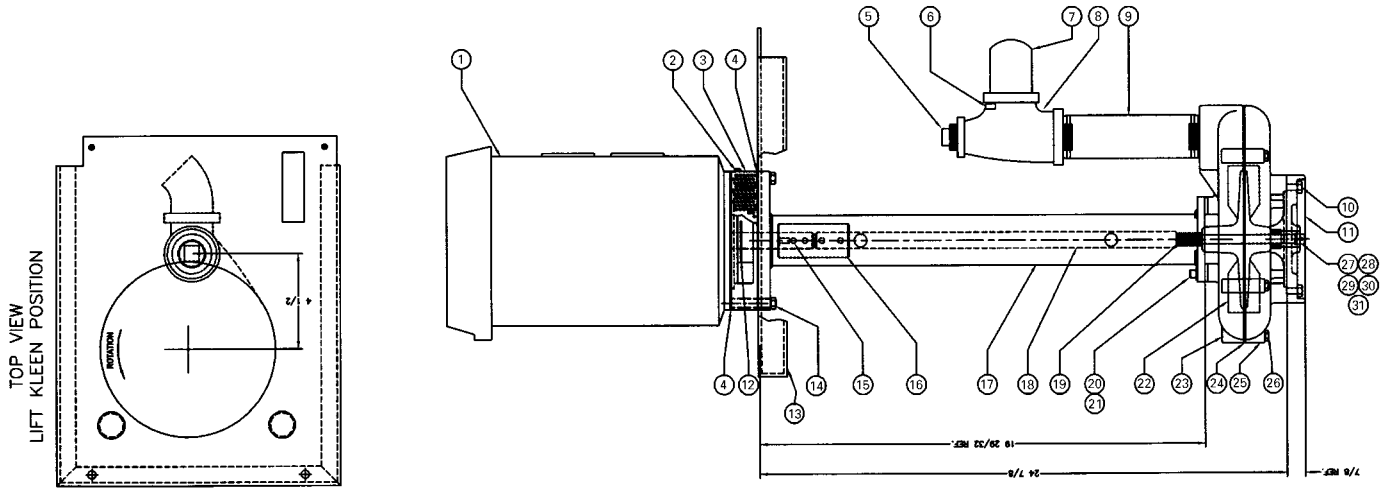

Note: For Teflon coated pumps and steam heated pumps consult factory.

PUMP ASSEMBLY

FIGURE 17

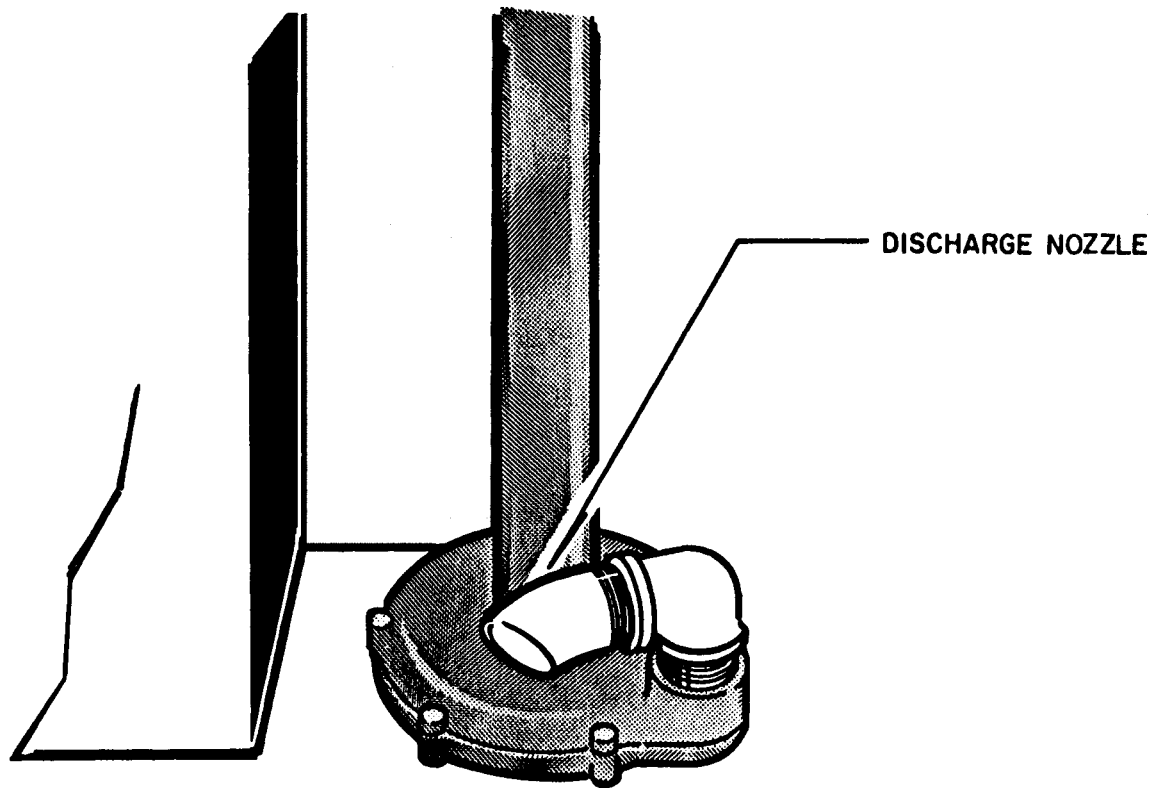

SUPERFLO PUMP DISCHARGE NOZZLE

FIGURE 18

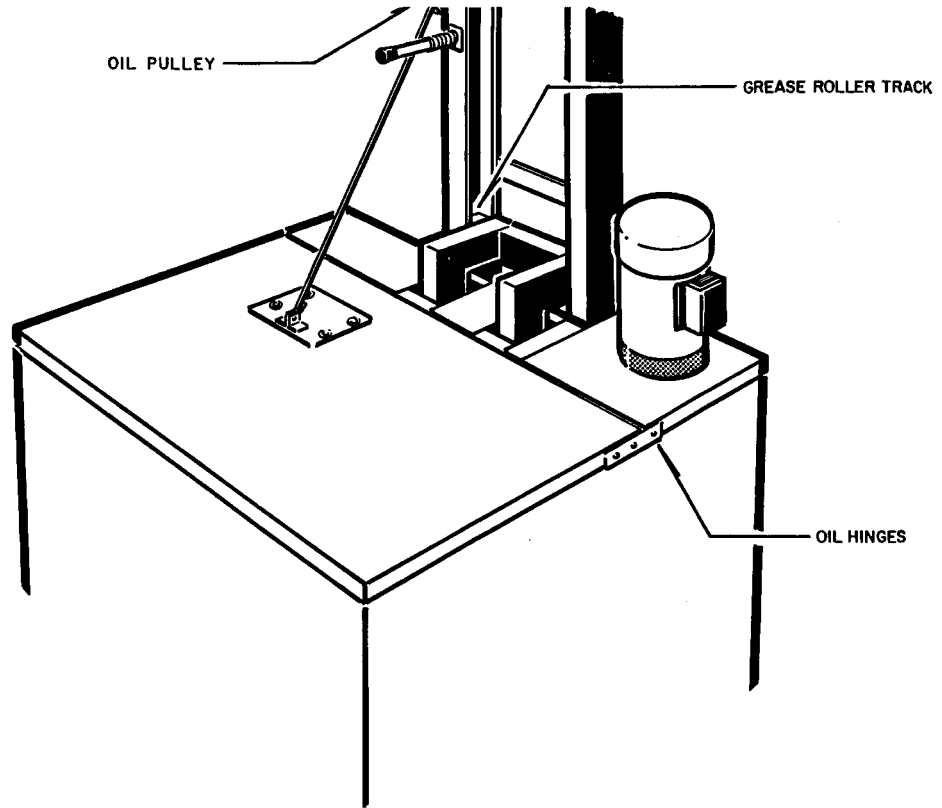

**LIFTING MECHANISM & LID ASSEMBLY
LUBRICATION POINT**

FIGURE 19

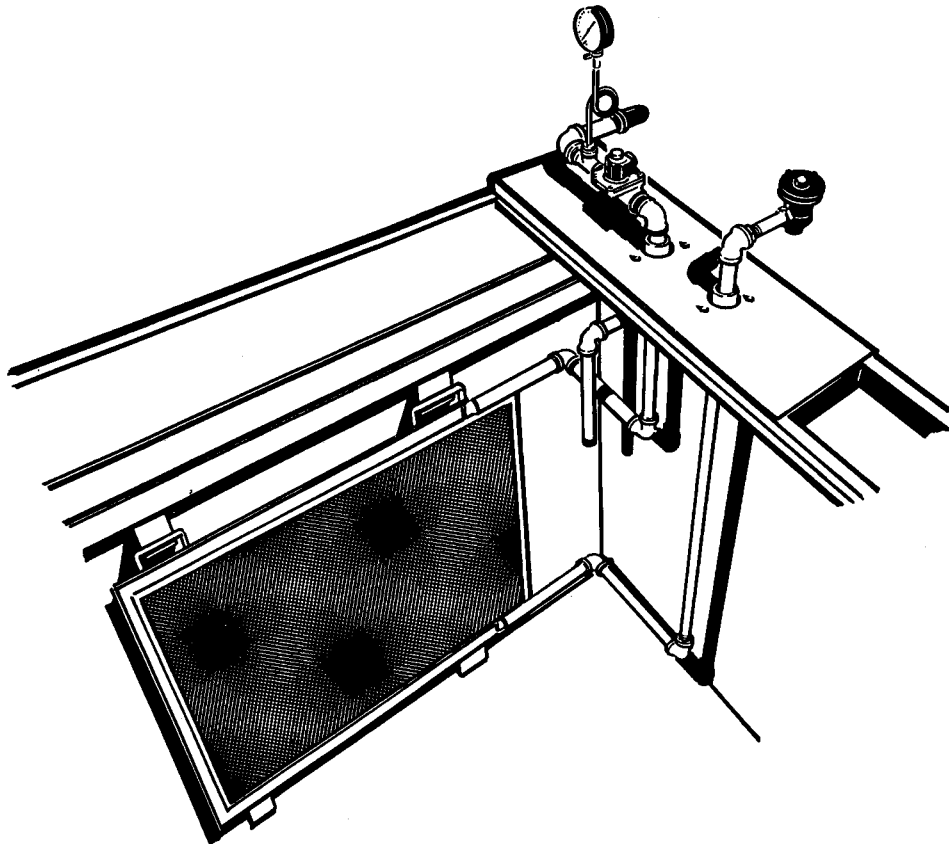

STEAM HEATING ARRANGEMENT

FIGURE 20

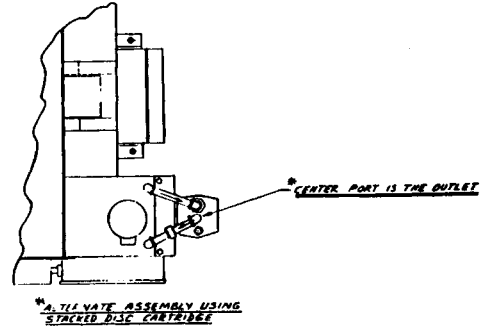
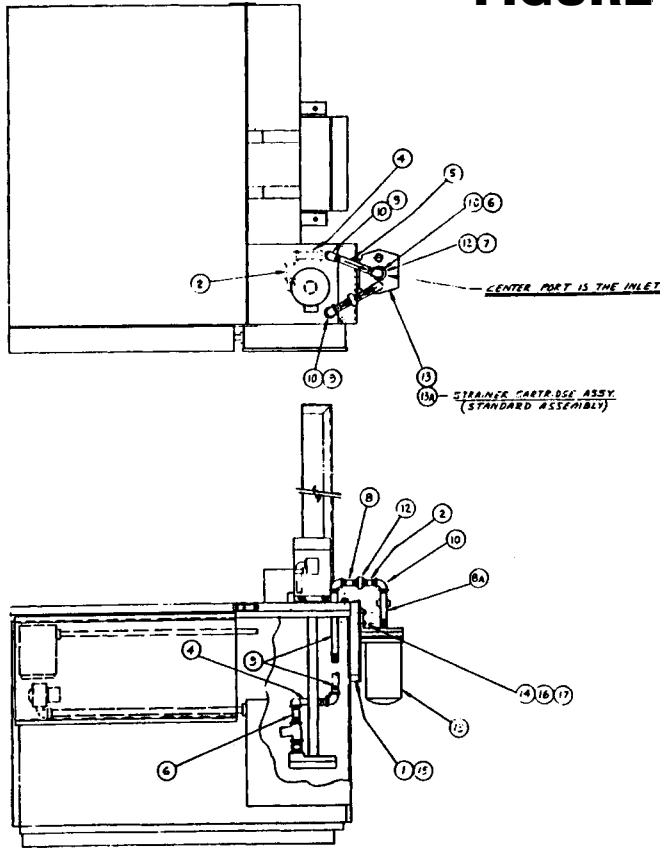

—NOTE—

1. PLUMBING CONNECTIONS ARE MADE AS FOLLOWS:

STRAINERS AND DISPOSABLE BAG ELEMENTS FLOW FROM INSIDE-OUT (CENTER PORT IS THE INLET)
 STACKED DISC ELEMENTS FLOW FROM OUTSIDE-IN (CENTER PORT IS THE OUTLET)

NOTE:

APPLY PIPE DOPE TO ALL CONNECTIONS

MODEL LKF-100 FILTRATION SYSTEM

FIGURE 21

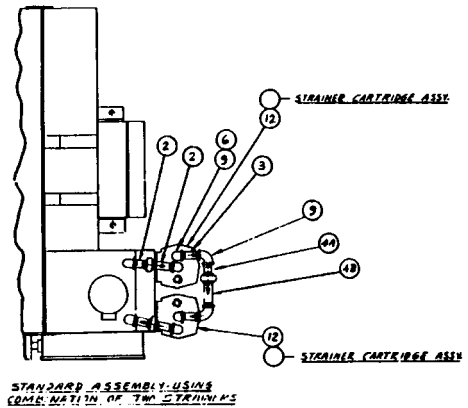
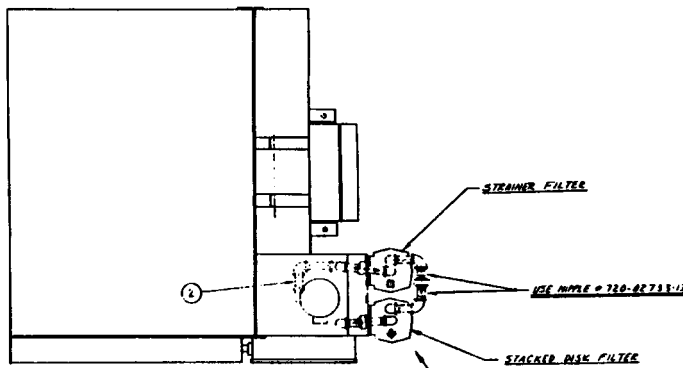

NOTE # 2 —
 ALTERNATE METHOD USING COMBINATION OF ONE STRAINER & ONE STACKED DISK

—NOTE—

1. PLUMBING CONNECTIONS ARE MADE AS FOLLOWS:

STRAINERS AND DISPOSABLE BAG ELEMENTS FLOW FROM INSIDE-OUT (CENTER PORT IS THE INLET)
 STACKED DISC ELEMENTS FLOW FROM OUTSIDE-IN (CENTER PORT IS THE OUTLET)

NOTE:

APPLY PIPE DOPE TO ALL CONNECTIONS

MODEL LKF-22 FILTRATION SYSTEM

FIGURE 22

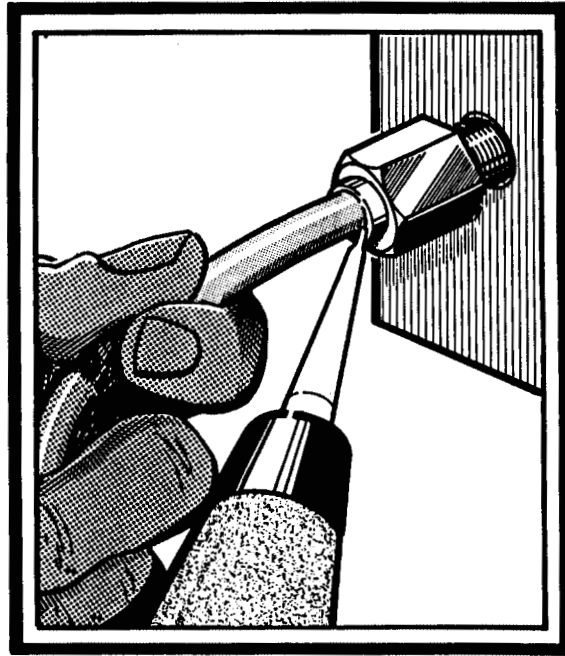

PNEUMATIC TUBING CONNECTION/DISCONNECT PROCEDURE